

# ADVANCED DETECTION SYSTEMS

## Conveyor System for Washdown Applications

### Welded Tube Frame

Our heavy-duty welded conveyor is constructed of bead blasted 304 stainless steel. Suitable for washdown environments and designed for bulk, packaged and big bag applications. Conveyor frame heights are tailored to your specific needs. Horizontal and incline construction is available. Multiple belt widths and lengths are offered. Welded frames can accommodate a wide variety of automatic reject devices.



To learn more, please contact us:

Phone: 414-672-0553

Email: [sales@adsdetection.com](mailto:sales@adsdetection.com)

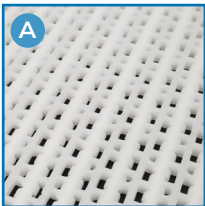

### The Intralox 1100 series

The Intralox 1100 series modular conveyor belt is longer lasting and easier to clean for a reduced risk of product loss due to contamination.

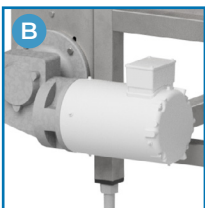

### Direct Drive

Washdown motor is totally enclosed and fan cooled. Stainless steel shaft and coated aluminum gear reducer.



### Touchscreen

Intuitive software and controls are easy to navigate. Make quick changes without disrupting production.

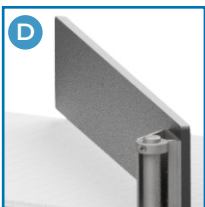

### Optional Reject Systems

Designed exactly for your application needs. All of our reject device options are suitable for use on the welded frame conveyor.

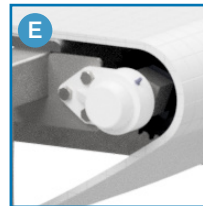

### Stainless Steel Ball Bearings

Protected inside polymer housing for washdown environments.

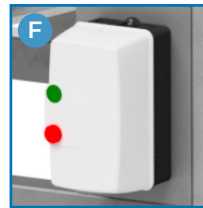

### Motor Starter

Watertight and corrosion resistant. Perfect for washdown environments.

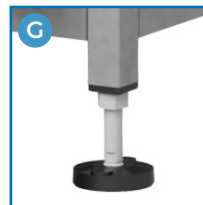

### Articulated Rubber Feet

Stable and reliable. Optional heavy-duty casters are available as well.



### Optional Detect Alert Beacon

Visual light and audible horn.

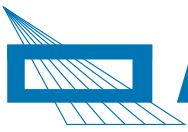

# ADVANCED DETECTION SYSTEMS

## Conveyor System for Washdown Applications

### ProScan Max<sup>®</sup> III Core Features



**Patented Vibration Technology**  
Improves performance and reliability when used in a vibration heavy environment.



**Acculearn<sup>™</sup> Technology**  
Our detectors quickly learn your products characteristics, in as few as two passes, eliminating false trips caused by product variability.



**Washdown Ready Construction**  
Our ProScan<sup>™</sup> metal detectors are designed to withstand the harshest washdown conditions.



**Custom Built**  
Our metal detectors are individually designed by our engineering staff and manufactured to your exact specifications.



**Guaranteed Sensitivity**  
We test your product and calibrate our detectors to your product's specific needs and guarantee sensitivity.



**Rugged Construction**  
Our optional all welded construction provided a durable and stable system for consistent metal detection.

### Welded Tube Frame Reject Device Options

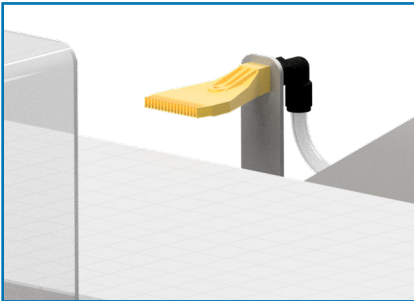

Air Blast  
(Light Weight Packages)

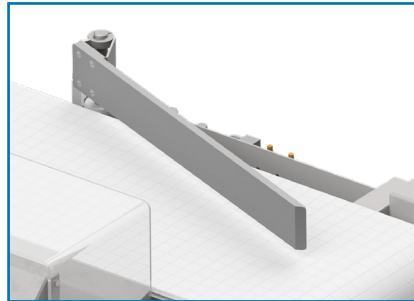

Sweep Arm  
(Packaged Product)

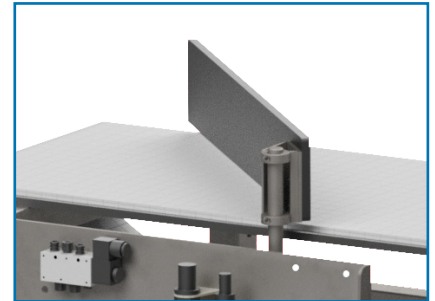

Divert Arm  
(Packaged Product)

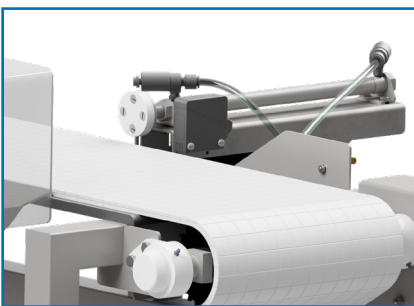

RAM (Push Arm)  
(Heavy Packaged Product)

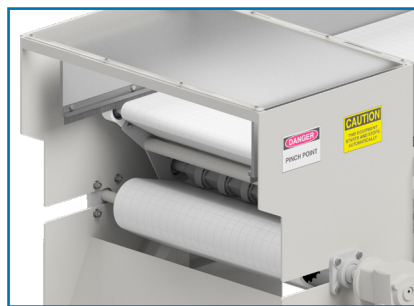

Retracting Pulley  
(Bulk Applications)

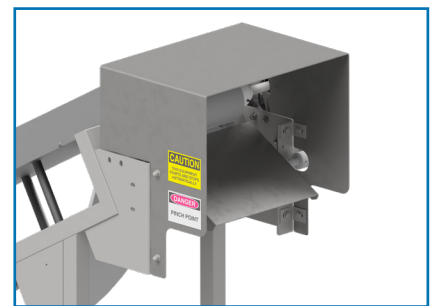

Flop Gate  
(Bulk Applications)



**ADVANCED  
DETECTION  
SYSTEMS**  
Metal Detection Experts

### Get Detection Optimized for Your Process

Have your product tested in our factory lab, free of charge. The results are used to optimize your ProScan's<sup>®</sup> detection levels for your specific product. We stand by this method with a written guarantee.